

**TECHNICAL MANUAL**

OPERATOR, ORGANIZATIONAL, DIRECT SUPPORT,  
AND GENERAL SUPPORT MAINTENANCE

WATTMETER  
AN/URM-120A

(SIERRA 164B-G3  
(NSN 6625-01-039-1488)

**This copy is a reprint which includes current  
Pages from Changes 1 and 2.**

**WARNING**

Always turn off the transmitter before inserting or removing the Bi-Directional Power Monitor from the transmission line. Failure to do so may result in severe RF burns to the user or in damage to the equipment.

CHANGE }  
NO. 2 }

**HEADQUARTERS  
DEPARTMENT OF THE ARMY  
WASHINGTON, DC, 9 JULY 1984**

**Operator's Organizational, Direct  
Support and General Support  
Maintenance Manual  
WATTMETER AN/URM-120A  
(SIERRA 164B-G3)  
(NSN 6625-01-039-1488)**

**WATTMETER AN/URM-120B  
(STRUTHERS 502-120-63)  
(NSN 6625-01-123-8098)**

TM 11-6625-2982-14, 12 May 1980, is changed as follows:  
The title of the manual is changed as shown above.  
*Page iii.* Reporting of Errors is superseded as follows:

**REPORTING ERRORS AND RECOMMENDING IMPROVEMENTS**

**You can help improve this manual. If you find any mistakes or if you know of a way to improve the procedures, let us know. Mail your letter, DA Form 2028 (Recommended Changes to publications and Blank Forms), or DA Form 2028-2 located in back of this manual direct to: Commander, US Army Communications-Electronics Command and Fort Monmouth, ATTN: DRSEL-ME-MP, Fort Monmouth NJ 07703. In either case, a reply will be furnished direct to you.**

**Page 1.** Paragraphs 0-1, 0-2, 0-3, 0-4 and 0-5 are superseded as follows:

### **0-1. Scope**

**a.** This manual describes Wattmeters AN/URM-120A and AN/URM-120B and provides maintenance instructions. Throughout this manual AN/URM-120A is referred to as the Sierra 164B-63 Bi-Directional Power Monitor Set and Wattmeter AN/URM-120B is referred to as the Struthers 502-120-G3 Bi-Directional Power Monitor Set.

**b.** Struthers 502-120-G3 Bi-Directional Power Monitor Set is being redesignated AN/URM-120B (NSN 6625-01-123-8098). The major assemblies are unchanged and the plug-in elements remain interchangeable with the AN/URM-120A.

**c.** The internal piece parts of the AN/URM-120B differ from the AN/URM-120A. For piece part ordering, reference the manufacturer and related part number.

### **0-2. Consolidated Index of Army Publications and Blank Forms**

Refer to the latest issue of DA Pam 310-1 to determine whether there are new editions, changes or additional publications pertaining to the equipment.

### **0-3. Maintenance Forms, Records and Reports.**

**a. Reports of Maintenance and Unsatisfactory Equipment.** Department of the Army forms and procedures used for equipment maintenance will be those prescribed by DA Pam 738-750 as contained in Maintenance Management Update.

**b. Report of Packaging and Handling Deficiencies.** Fill out and forward SF 364 (Report of Discrepancy (ROD)) as prescribed in AR 735-11-2/DLAR 4140-55/NAVMATINST 4355.73A/AFR 400-54/MCO 4430.3F.

**c. Discrepancy in Shipment Report (DISREP) (SF 361).** Fill out and forward Discrepancy in Shipment Report (DISREP) (SF 361) as prescribed in AR 55-38/NAVSUPINST 4610.33C/AFR 75-18/MCO P4610.19D/DLAR 4500.15.

### **0-4. Reporting Equipment Improvement Recommendations (EIR)**

If your Wattmeter AN/URM-120A or AN/URM-120B needs improvement, let us know. Send us an EIR. You, the user, are the only one who can tell us what you don't like about your equipment. Let us know why you don't like the design. Put it on an SF 368 (Quality Deficiency Report). Mail it to Commander, US Army Communications-Electronics Command and Fort Monmouth, ATTN: DRSEL-ME-MP, Fort Monmouth, New Jersey 07703. We'll send you a reply.

### **0-5. Administrative Storage**

Administrative storage of equipment issued to and used by Army activities will have preventive maintenance performed in accordance with the PMCS charts before storing. When removing the equipment from administrative storage the PMCS should be performed to assure operational readiness. Disassembly and repacking of equipment for shipment or limited storage are covered in paragraphs 6.11 and 7.01.

By Order of the Secretary of the Army:

Official:

**JOHN A. WICKHAM JR.**  
*General, United States Army*  
*Chief of staff*

ROBERT M. JOYCE  
*Major General, United States Army*  
*The Adjutant General*

**DISTRIBUTION:**

To be distributed in accordance with DA Form 12-36B, Operator Maintenance requirements for AN/URM-120.



CHANGE }  
No. 1 }

HEADQUARTERS  
DEPARTMENT OF THE ARMY  
WASHINGTON, DC, 7 JANUARY 1983

**Operator's Organizational, Direct  
Support and General Support  
Maintenance Manual  
WATTMETER AN/URM-120A  
(SIERRA 164B-G3)  
(NSN 6625-01-039-1488)**

TM 11-6625-2982-14, 12 May 1980, is changed as follows:  
The title of the manual is changed as shown above.  
*Page iii.* Reporting of Errors is superseded as follows:

**REPORTING ERRORS AND RECOMMENDING IMPROVEMENTS**  
You can help improve this manual. If you find any mistakes or if you know of a way to improve the procedures, let us know. Mail your letter or DA Form 2028 (Recommended Changes to Publications and Blank Forms), direct to: Commander, US Army Communications-Electronics Command and Fort Monmouth, ATTN: DRSEL-ME-MR, Fort Monmouth, NJ 07703. In either case, a reply will be furnished direct to you.

*Page 1.* Paragraphs 0-1, 0-2, 0-3, 0-4 and 1.01 are superseded as follows:

**0.1. Scope**

This manual describes Wattmeter AN/URM-120A and provides maintenance instructions. Throughout this manual Wattmeter AN/URM-120A is referred to as the Sierra 164B-G3 Bi-Directional Power Monitor Set, or Struthers 502-120-G3 Bi-Directional Power Monitor Set.

**0.2. Index of Technical Publications**

Refer to the latest issue of DA Pam 310-4 to determine whether there are new editions, changes or additional publications pertaining to the equipment.

**0-3. Maintenance Forms, Records and Reports**

*a. Reports of Maintenance and Unsatisfactory Equipment.* Department of the Army forms and procedures used for equipment maintenance will be those prescribed by TM 38-750, The Army Maintenance Management System.

*b. Report of Packaging and Handling Deficiencies.* Fill out and forward SF 364 (Report of Discrepancy (ROD)) as prescribed in AR 735-11-2/DLAR 4140.55/NAVMATINST 4355.73/AFR 400-54/MCO 4430.3E.

*c. Discrepancy in Shipment Report (DISREP) (SF 361).* Fill out and forward Discrepancy in Shipment Report (DISREP) (SF 361) as prescribed in AR 55-38/NAVSUPINST 4610.33B/AFR 75-18/MCO P4610.19C/DLAR 4500.15.

**0-4. Reporting Equipment Improvement Recommendations (EIR)**

If your Wattmeter AN/URM-120A needs improvement, let us know. Send us an EIR. You, the user, are the only one who can tell us what you don't like about your equipment. Let us know why you don't like the design. Tell us why a procedure is hard to perform. Put it on and SF 368 (Quality Deficiency Report). Mail it to Commander, US Army Communications-Electronics Command and Fort Monmouth, ATTN: DRSEL-ME-MP, Fort Monmouth, New Jersey 07703. We'll send you a reply.

**TM 11-6625-2982-14**

1.01. This Manual covers the Sierra 164B-G3 Bi-Directional Power Monitor Set. Included are descriptions, specifications, operation, maintenance, and a replaceable parts list. The components of the Bi-Directional Power Monitor Set are as follows (see fig. 1):

- Bi-Directional Power Monitor (164B, Sierra)  
(Struthers 1219-D001-G)
- Plug-in Element (181A-250, Sierra)  
(Struthers 1219-D-204)
- Plug-in Element (181A-1000, Sierra)  
(Struthers 1219-D-205)

- Plug-in Element (270A-30, Sierra)  
(Struthers 1219-D-008-G2)
- Carrying Case (164B-CC, Sierra)  
(Struthers C105037)

Page 3. The following NOTE is added before Table 3-2.

**NOTE**

For cross-reference of Struthers part numbers see page 1, paragraph 1.01.

Page 10. Table 8-1. Replaceable Parts List. The following is added after the last line of Table 8-1.

Table 8-1. Replaceable Parts List—Continued

Ref. Desig.	Description	Struthers' Stock No.	Mfr.	Mfr. Part No.
C1	MODEL 1219-D-001-G Capacitor, Ceramic 0.01UF 450VDC		Erie	811000
J1	Connector, Female, Type N	A100537	Struthers	
J2	Connector, Male, Type N	A100536	Struthers	
M1	Meter 25 Microamperes DC	C101727	Struthers	
P1	Plug-nut Assembly	A101878-1	Struthers	
R1	Potentiometer-Switch Assembly 10K ohms	A101927	Struthers	
R2	Resistor 150 ohms		Mil-Std	RCR20G151JS
S1	Part of R1 Knob, Instrument Bumper, Foot, rubber		Herman H. Smith Atlantic India Rubber Works	2391 253
	Cushion, Core, rubber Strap, Carrying	A1219-D-47 A100545	Struthers Struthers	
	MODEL 1219-D-008-G2 Knob Decal Cap, Protective Power Selection Plate Model 1219-D-204 Knob Decal Cap, Protective Power Selection Plate Model 1219-D-205 Knob Decal, Arrow Cap, Protective Power Selection Plate	A101723 A101923-2 B104944-1 A101723 A101923-2 B104940-1 A101723 A101923-2 B104943-1	Struthers Struthers Protective Enclosure Struthers Struthers Struthers Protective Closures Struthers Struthers Struthers Protective Closure Struthers	221 221

Page D-3. Appendix D, Section II - Maintenance Allocation Chart. The following NOTE is added to Column (2) Component/Assembly, after the last line.

**NOTE**

For cross-reference of Struthers part numbers see page 1, paragraph 1.01.



By Order of the Secretary of the Army:

Official:

**ROBERT M. JOYCE**  
*Major General, United States Army*  
*The Adjutant General*

**E. C. MEYER**  
*General, United States Army*  
*Chief of Staff*

**DISTRIBUTION:**

To be distributed in accordance with Special Mailing List.





**5** SAFETY STEPS TO FOLLOW IF SOMEONE IS THE VICTIM OF ELECTRICAL SHOCK

- 1** DO NOT TRY TO PULL OR GRAB THE INDIVIDUAL
- 2** IF POSSIBLE, TURN OFF THE ELECTRICAL POWER
- 3** IF YOU CANNOT TURN OFF THE ELECTRICAL POWER, PULL, PUSH, OR LIFT THE PERSON TO SAFETY USING A WOODEN POLE OR A ROPE OR SOME OTHER INSULATING MATERIAL
- 4** SEND FOR HELP AS SOON AS POSSIBLE
- 5** AFTER THE INJURED PERSON IS FREE OF CONTACT WITH THE SOURCE OF ELECTRICAL SHOCK, MOVE THE PERSON A SHORT DISTANCE AWAY AND IMMEDIATELY START ARTIFICIAL RESUSCITATION

## WARRANTY

SIERRA ELECTRONIC DIVISION, LEAR SIEGLER, INC. warrants products manufactured by it to be free from defects in material and workmanship and to meet the applicable specifications under normal use and service for a period of 12 months from the date of original shipment by us. Our obligation under this warranty is limited to the repair or replacement of such products which, after having been returned to the factory or a point designated by us, shall be examined and in our sole opinion, found defective and that such defect was not induced by causes external to the product. Alternately, SIERRA may elect to issue credit for any such defective product. All products to be repaired or replaced shall be returned prepaid to the designated place of repair in accordance with authorization and packing and shipping instructions issued by SIERRA. Return shall not be made until such authorization and instructions are issued. Each returned product shall be accompanied by a statement or report fully stating the claimed defects and any other pertinent information concerning the failure.

SIERRA'S responsibility under this warranty does not apply to any products which have been repaired, worked upon or altered by persons not authorized by us so as to in our sole judgement, injure the stability or reliability of such product, or which have been subject to misuse, negligence or accident, or where applicable, the serial number has been altered, effaced or removed. SIERRA shall not be liable for damages resulting from the use of the purchased product, nor shall SIERRA be responsible for any failure in the performance of other items to which the purchased product is connected or the functioning of an entire system or parts of any system of which the purchased product may be a part.

SIERRA reserves the right to make changes in the design or construction of any of its products at any time without incurring any obligation to make changes whatever on units previously purchased. Accessories, including but not limited to all vacuum tubes, fuses, pilot lamps and batteries used with our products are not covered by this warranty. A test setup charge of \$25.00 will apply to any returned instrument or microwave component which, after test, is found to meet the applicable specifications.

This warranty is in lieu of all other warranties, expressed, implied or statutory. No representative or person is authorized to represent nor assume for SIERRA any liability in connection with the sale of products other than set forth herein. IN NO EVENT SHALL SIERRA BE LIABLE FOR SPECIAL INCIDENTAL OR CONSEQUENTIAL DAMAGES.

TM 11-6625-2982-14

TECHNICAL MANUAL

NO. 11-6625-2982-14

HEADQUARTERS  
DEPARTMENT OF THE ARMY  
WASHINGTON, D.C.  
May 12, 1980

**ORGANIZATIONAL, DIRECT SUPPORT, AND GENERAL SUPPORT MAINTENANCE MANUAL  
FOR**

**WATTMETER AN/URM-120A  
(SIERRA 164B-G3)  
(NSN 6625-01-039-1488)**

**REPORTING OF ERRORS**

You can improve this manual by recommending improvements using DA Form 2028-2 located in the back of the manual. Simply tear out the self-addressed form, fill it out as shown on the sample, fold it where shown, and drop it in the mail.

If there are no blank DA Forms 2028-2 in the back of your manual, use the standard DA Form 2028 (Recommended Changes to Publications and Blank Forms) and forward to the Commander, US Army Communications and Electronics Materiel Readiness Command, ATTN: DRSEL-ME-MQ, Fort Monmouth, NJ 07703.

In either case a reply will be furnished direct to you.

This manual is an authentication of the manufacturer's commercial literature which, through usage, has been found to cover the data required to operate and maintain this equipment. The manual was not prepared in accordance with military specifications; therefore, the format has not been structured to consider categories of maintenance.

TABLE OF CONTENTS

Para		Page
0.	INSTRUCTIONS . . . . .	1
1.	GENERAL . . . . .	1
2.	DESCRIPTION . . . . .	2
3.	SPECIFICATIONS . . . . .	2
4.	THEORY OF OPERATION . . . . .	4
	Line and Meter Unit . . . . .	4
	Plug-in Elements . . . . .	4
5.	OPERATION . . . . .	4
	Insertion of Plug-in Elements . . . . .	4
	Removal of Plug-in Elements . . . . .	5
	Incident Power Measurement . . . . .	5
	Reflected Power Measurement . . . . .	5
	VSWR . . . . .	5
	Power Absorbed by Load . . . . .	6
	Percentage of Modulation . . . . .	6
	Directivity Error . . . . .	6
	Application Note . . . . .	8
6.	MAINTENANCE . . . . .	8
	Cleaning and Lubrication . . . . .	8
	Inspection . . . . .	8
	Performance Verification . . . . .	9
	Troubleshooting . . . . .	9
	Disassembly, Repair, and Replacement . . . . .	9
7.	STORAGE AND RESHIPMENT . . . . .	9
8.	REPLACEABLE PARTS . . . . .	9
	APPENDIX A – REFERENCES . . . . .	A-1
	APPENDIX B – COMPONENTS OF END ITEM LIST (Not Applicable)	
	APPENDIX C – ADDITIONAL AUTHORIZATION LIST (Not Applicable)	
	APPENDIX D – MAINTENANCE ALLOCATION . . . . .	D-1

**0. INSTRUCTIONS**

**0-1. Scope.**

This manual describes Wattmeter AN/URM-120A and provides maintenance instructions. Throughout this manual, Wattmeter AN/URM-120A is referred to as the Sierra 164B-G3 Bi-Directional Power Monitor Set.

**0-2. Indexes of Publications.**

a. DA Pam 310-4. Refer to the latest issue of DA Pam 310-4 to determine whether there are new editions, changes, or additional publications pertaining to the equipment.

b. DA Pam 310-7. Refer to DA Pam 310-7 to determine whether there are modification work orders (MWO's) pertaining to the equipment.

**0-3. Forms and Records.**

a. Reports of Maintenance and Unsatisfactory Equipment. Maintenance forms, records, and reports which are to be used by maintenance personnel at all levels of maintenance are listed in and prescribed by TM 38-750.

b. Report of Packaging and Handling Deficiencies. Fill out and forward DD Form 6 (Packaging Improvement Report) as prescribed in AR 700-58/NAVSUPINST 4030.29/AFR 71-13/MCO P4030.29A and DSAR 4145.8.

c. Discrepancy in Shipment Report (DISREP) (SF 361). Fill out and forward Discrepancy in Shipment Report (DISREP) (SF 361) as prescribed in AR 55-38/NAVSUPINST 4610.33A/AFR 75-18/MCO P4619.19B and DSAR 4500.15.

**0-4. Reporting of Equipment Improvement Recommendations (EIR).**

EIRs will be prepared using DA Form 2407, Maintenance Request. Instructions for preparing EIRs are provided in TM 38-750, The Army Maintenance Management System. EIR's should be mailed directly to Commander, US Army Communications and Electronics Materiel Readiness Command, ATTN: DRSEL-ME-MQ, Fort Monmouth, New Jersey 07703. A reply will be furnished directly to you.

**0-5. Administrative Storage.**

Administrative storage of equipment issued to and used by Army activities shall be in accordance with TM 740-90-1.

**0-6. Destruction of Army Electronics Materiel.**

Destruction of Army electronics materiel to prevent enemy use shall be in accordance with TM 750-244-2.

**1. GENERAL**

1.01 This manual covers the Sierra 164B-C3 Bi-Directional Power Monitor Set. Included are description, specifications, operation, maintenance, and a replaceable parts list. The components of the Bi-Directional Power Monitor Set are as follows (see Figure 1):

Bi-Directional Power Monitor 164B

Plug-in Element 181A-250

Plug-in Element 181A-1000

Plug-in Element 270A-30

Carrying Case 164B-CC.

1.02 The Bi-Directional Power Monitor Set is a compact, versatile instrument for intermittent or continuous measuring of incident and reflected power or precise convenient matching of loads to lines. Power is read directly on a linear scale with accuracy of  $\pm 5\%$ . The meter is also calibrated to read VSWR directly. So long as incident power is above a minimum requirement, a simple adjustment makes it possible to read VSWR directly from the meter scale.

1.03 Principal features of the 164B-G3 are:

- Measures incident and reflected power, 2 MHz to 1000 MHz.
- Any one of the plug-in elements offers a selection of four switchable power levels over a given frequency range.
- Covers a power range from 100 mw to 1000 watts, depending on frequency (see Table 3-2).
- Meter reads VSWR directly.
- Designed to operate in 50-ohm coaxial systems.

1.04 The 164B measures power flowing in 50-ohm coaxial transmission line systems. Using specially designed plug-in elements, the instrument measures incident or reflected average power up to 1000 watts. The meter

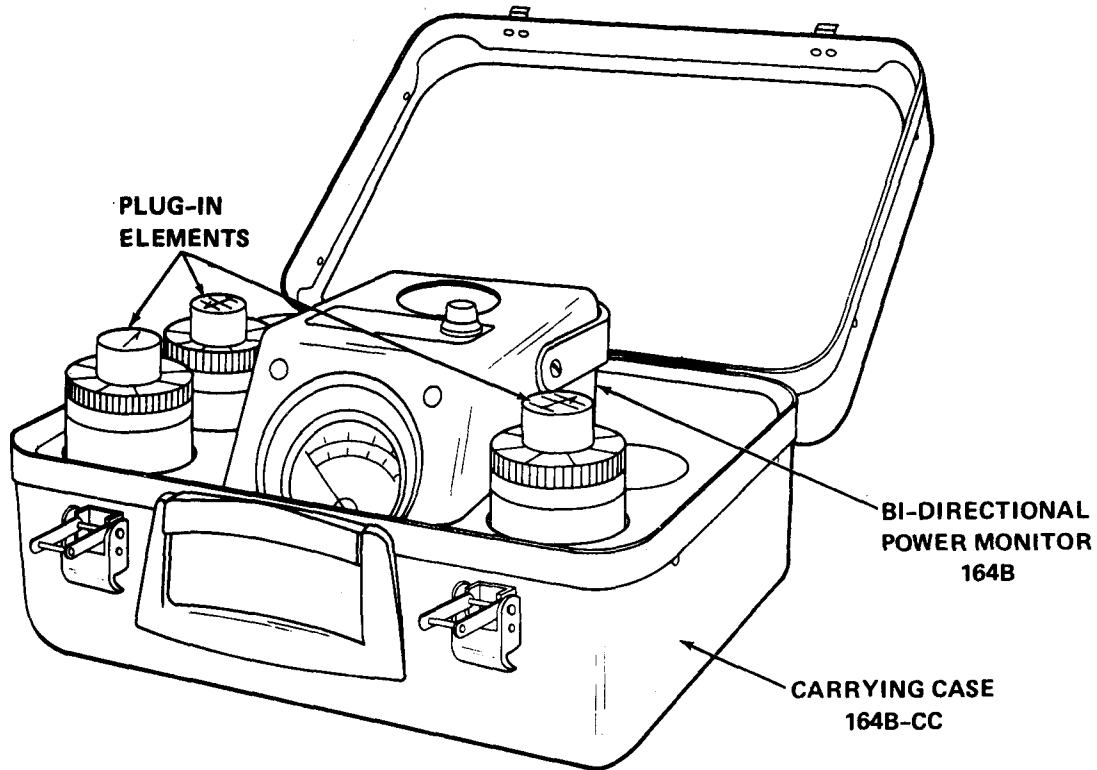

**Figure 1. Sierra 164B-G3 Bi-Directional Power Monitor Set**

scale is also calibrated to read VSWR directly. The frequency range covered is 2 to 1000 megahertz. Each element covers a specific frequency range and four power ranges. (See Table 3-2.)

1.05 The 164B is designed to be connected in series with the coaxial transmission line being tested at any point between the rf source and the load. Rotation of the element is all that is required to read incident or reflected power in any power range.

## 2. DESCRIPTION

2.01 The 164B is contained in a small, lightweight metal case. The indicating meter is shock mounted in a die-cast case to provide protection in normal field use. This case is equipped with a carrying strap for maximum portability. All other parts are of rugged construction to assure continuous service and long life. Both meter and plug-in element may be easily removed from the case for remote monitoring.

2.02 The plug-in element projects through a hole in the top of the case. On the exposed end of the element there is an etched dial and a knob by which the desired power range is selected. The outer rim of the element is knurled so that it may be easily turned. 180 degrees ro-

tation selects the direction in which power flow along the coaxial line is to be measured. A pin stop determines the element position in either direction.

2.03 Plug-in Elements 181A-250 and 270A-30 have a frequency correction chart mounted on the power range selector knob. The multiplier is to be applied to power readings taken at or near the frequencies indicated. No correction is required for the remainder of the frequency range.

2.04 The upper and lower parts of the case are held together with fasteners which permit easy access to the element, the primary line body and the indicating meter. The case must be opened in order to remove or replace the element. Three nylon wedges hold the insert firmly in place. These wedges are held in position by a clamp located on the primary line body.

2.05 The instrument is entirely self-contained and requires no external source of power, aside from that which is being measured.

## 3. SPECIFICATIONS

3.01 Table 3-1 lists the overall specifications for the 164B-G3.



**Table 3-1. Bi-Directional Power Monitor Set Specifications**

Meter Scales		
Watts		0-10, 0-25, 0-50
VSWR		1-20
Power Ranges		See Table 3-2
Frequency Ranges		See Table 3-2
Impedance, Primary Line		50 ohms, coaxial
Accuracy		
Incident Power		±5% of full scale
Reflected Power		±5% of full scale (reflected power range) + $\frac{\text{measured incident power}}{\text{numerical directivity ratio of plug-in element}}$
RF Connectors		One male, one female Type N
Dimensions (inches)		
Carrying Case		7-1/8 high x 12-1/2 wide x 10-5/16 deep
Power Monitor		6-5/8 high x 7 wide x 7-7/16 deep
Plug-in Element		4-1/4 high x 2-5/16 diameter
Weight (pounds)		
Total		14.3
Carrying Case (empty)		4.4
Power Monitor		6.6
Plug-in Element		1.1 each

**Table 3-2. Plug-in Element Specifications**

Model	Freq. (MHz)	Power Range (Watts)	Insertion VSWR		Lowest Power Range Directivity	
			Lowest Power Range	Highest Power Range	Numerical Ratio	dB
181A-250	25-250	10, 50, 100, 500	1.08	1.05	1000:1	30
181A-1000	200-1000	10, 50, 100, 500	1.08	1.05	1000:1	30
270A-30	2-30	50, 100, 500, 1000	1.08	1.08	160:1	22

## 4. THEORY OF OPERATION

### Line and Meter Unit

4.01 The 164B is made up of a 50 ohm coaxial primary line section and an indicating meter mounted in a suitable case. The primary line section is so designed that when the element is properly clamped in place there will be a minimum effect on the VSWR of the line. The meter is a sensitive 25 microammeter that reads directly the output of the element to indicate power. When switched to the direct reading VSWR position, a calibrating network is connected across the meter. See Schematic Diagram Figure 2.

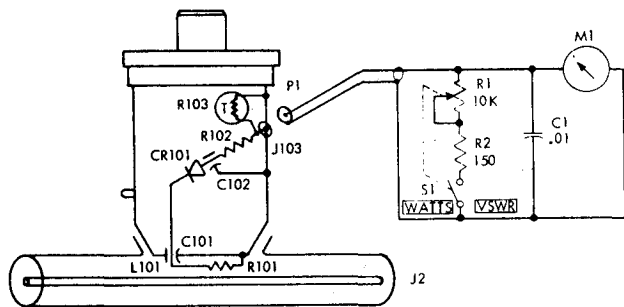

Figure 2. Bi-Directional Power Monitor, Schematic Diagram

### Plug-in Elements

4.02 The Plug-in Elements contain the directional coupler and the remainder of the meter circuitry.

4.03 The secondary line loop, L101, terminated on one end with R101 and on the other end by the meter rectifier diode, CR101, forms the directional coupler (see Figure 2). C101 and the rf input resistance to the rectifier diode are a frequency compensating circuit that provides a constant coupling factor. C102 is a storage capacitor and R102 the rectifier diode load resistance. R102 also serves as the meter sensitivity resistor. R103 is a temperature compensating thermistor.

4.04 Power from one direction in the primary line is coupled into the secondary line loop and rectified. The dc output of the rectifier is indicated by the meter. Because of the rectifier characteristics and the circuit parameters, the meter reads average power directly on a linear scale.

4.05 The directional coupler loop and the meter rectifier components are mounted on a spring loaded sliding assembly within the plug-in element. The knob on top of the plug-in element operates a cam that precisely

adjusts the distance the coupling loop projects into the primary line by positioning the sliding assembly. The position of the sliding assembly is adjustable, for calibration purposes, by four screws mounted inside the unit. The four coupling loop positions determine the power ranges of the plug-in element.

## 5. OPERATION

5.01 This section contains detailed operation instructions for the use of the equipment. The operating instructions include routines for insertion and removal of the plug-in elements, incident power measurement, reflected power measurement and VSWR power measurement.

### Insertion of Plug-in Elements

5.02 The following steps should be taken when inserting the plug-in element.

#### Step 1

Loosen fasteners and lift off the top of the case.

#### Step 2

Set the power range knob to the highest power range. This retracts the coupling loop within the recess and protects it from damage.

**CAUTION:** Bending or distortion of the coupling loop will destroy the instrument's calibration. Keep loop end of plug-in element covered with protective plastic cap when not in use.

#### Step 3

Release the wedge clamp buckle and follow lubrication instructions of 6.02.

#### Step 4

Orient the plug-in element so the pin on the side will fit into the recessed position of the seat on the primary line body.

#### Step 5

Place the element in position and close the wedge clamp buckle. The nylon wedges fit into a circular groove on the element. The pin engages a spring clip at each end of rotational travel so that it is held in either the forward or reverse reading position.

#### Step 6

Connect meter cable to connector on side of the element.

**Step 7**

Replace the top of the case. Be sure the meter cable is inside the case and not pinched between the two sections of the case.

**Removal of Plug-in Elements**

5.03 The following steps should be followed when removing the plug-in element.

**Step 1**

Loosen fasteners and lift off the top of the case.

**Step 2**

Disconnect meter cable from connector on the side of the element.

**Step 3**

Set the power range knob to the highest power range.

**Step 4**

Open clamp wedge buckle and withdraw the element.

**Step 5**

Place a protective plastic cap over the end of the element.

**Incident Power Measurement**

5.04 The following steps should be taken when performing incident power measurement tests.

**Step 1**

Remove all RF power from the transmission line that is to be tested.

**Step 2**

Connect the 164B, with the appropriate plug-in element installed, into the transmission line between the RF source and the load.

**Step 3**

Set the function switch (on VSWR CAL control) in the WATTS position.

**Step 4**

Place the power range knob of the element in the highest power range position.

**Step 5**

Rotate the element so that the power flow indicating arrow points toward the load.

**NOTE:** After the 164B has been installed in the transmission line the element may be rotated without removing the RF power from the line.

**Step 6**

Apply RF power to the line under test.

**Step 7**

Select the power range that will give a convenient reading on the meter.

**CAUTION:** Use care in selecting the power range setting. The meter or rectifier diode may be damaged by overloads exceeding 300% of full scale.

**Reflected Power Measurement**

5.05 The following steps should be taken when performing reflected power measurement tests.

**Step 1**

If the 164B is not already connected into the transmission line follow steps 1 through 4 of paragraph 5.04.

**Step 2**

Rotate the element so that the power flow indicating arrow points toward the RF source.

**Step 3**

Select the power range that will give a convenient reading on the meter.

**Step 4**

Place the power range knob in the highest power range position before rotating the element to read incident power.

**VSWR**

5.06 The following steps should be taken when performing VSWR power measurement tests.

**USING DIRECT READING VSWR SCALE**

**Step 1**

Check the power in transmission line using the procedure outlined in paragraph 5.04.

**NOTE:** Power available must be about 20% greater than the maximum of the lowest range of the element used. This is due to the effect on the meter of the VSWR calibrating circuit. If required power is not being

transmitted, use a lower range element or increase power in the transmission line.

**Step 2**

Turn on the function switch (on VSWR CAL control) to VSWR CAL position.

**Step 3**

Turn the element to the next power range.

**Step 4**

Adjust the VSWR CAL control until meter reads on CAL mark of VSWR.

**Step 5**

Turn the element to reflected power position (arrow pointing toward power source).

**Step 6**

Read VSWR scale.

**NOTE:** A more exact determination of VSWR may be made by using the procedure involving the VSWR chart.

**USING THE VSWR CHART**

**Step 1**

If the 164B is not already connected into the transmission line, follow steps 1 through 4 above, under "Using Direct Reading VSWR Scale."

**Step 2**

Read the incident power and record reading.

**Step 3**

Read the reflected power and record reading.

**Step 4**

Enter the recorded readings on a copy of the VSWR chart, Figure 3, and read the VSWR at the intersection of these readings.

**EXAMPLE:** Incident power is 500 watts, reflected power is 20 watts. Enter these readings on the chart and the VSWR should read 1.5. Figure 3 is based on the equation:

$$VSWR = \frac{\sqrt{P_i} + \sqrt{P_r}}{\sqrt{P_i} - \sqrt{P_r}} \quad \text{Where } P_i = \text{Incident Power}$$

$$P_r = \text{Reflected Power}$$

This equation may be used for exact determination of intermediate points.

**Power Absorbed by Load**

5.07 The radio frequency power absorbed by the load may be determined by subtracting the reading of the reflected power from the reading of the incident power. For example: If the incident power reading is 50 watts, and the reflected power reading is 5.5 watts, the power absorbed by the load is 50-5.5 or 44.5 watts.

**Percentage of Modulation**

5.08 The average power of an amplitude modulated carrier increases over the CW level because of the additional power developed in the side bands. Provided the modulation is symmetrical, the modulation percentage of such a modulated carrier may be determined as follows:

**Step 1**

Determine the power of the carrier without modulation.

**Step 2**

Determine the power of the modulated carrier.

**Step 3**

Apply the following equation:

$$\text{Percentage of Modulation} = 141 \sqrt{\frac{P_m}{P_{cw}} - 1}$$

where

$P_m$  = Power under modulated conditions

$P_{cw}$  = Power under CW conditions

**NOTE:** If carrier frequency shift is present it will introduce an error into this measurement.

**Directivity Error**

5.09 The effect of imperfect directivity of the plug-in directional coupler for incident power readings is included within the specified accuracy of  $\pm 5\%$ . The effect on reflected power readings is according to the following equation:

$$\text{Error} = \pm 5\% \text{ full scale (reflected power range) + } \frac{\text{Measured incident power}}{\text{Numerical directivity ratio}}$$

**EXAMPLE A:** Incident power is 40 watts, reflected power is 2 watts, read on the 5 watt scale; plug-in element numerical directivity ratio is 300:1 (25 db).

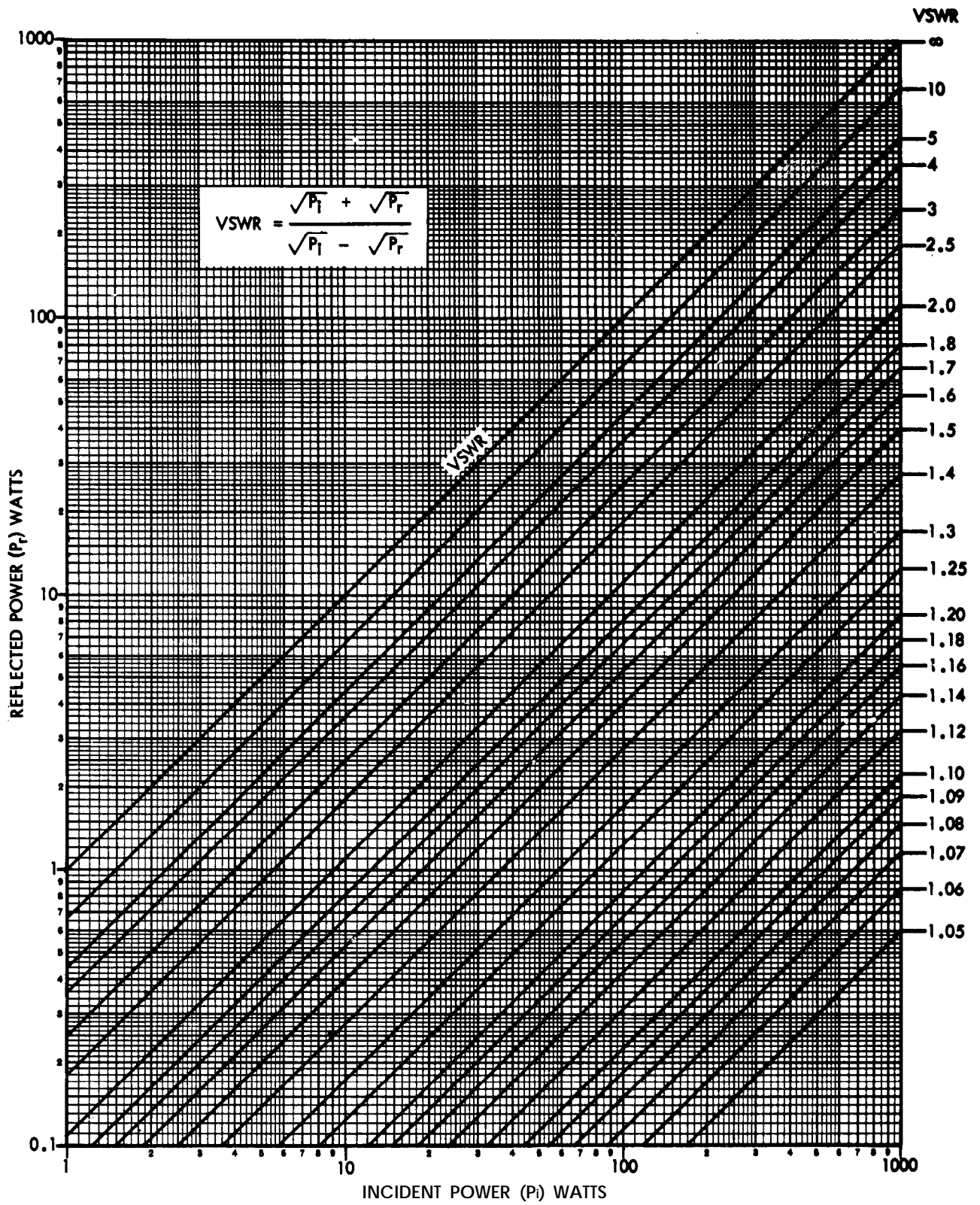

Figure 3. VSWR Chart

Directivity error is:

$$\pm 0.05 \times 5 + \frac{40}{300} = \pm 0.38 \text{ watt}$$

**EXAMPLE B:** The above conditions of measured power, but the numerical directivity ratio of the plug-in element is 100:1 (20 db). Directivity error is:

$$\pm 0.05 \times 5 + \frac{40}{100} = \pm 0.65 \text{ watt}$$

### Application Note

5.10 Under certain conditions insertion of the Power Monitor into the transmission line may cause a change in the rf power delivered to the load. This condition is usually observed when the power source is operating with a load that is not matched to the transmission line. When the Power Monitor is inserted the short section of line contained in the Monitor changes the electrical length of the system and therefore causes a change in the impedance into which the power source works. This condition may be handled by one of the following methods:

1. Retune or readjust the rf power source for delivery of normal power to the load.
2. Add a section of transmission line to the 164B Power Monitor such that the combined length of the added section plus that in the 164B equals one half wavelength for the frequency in use. Remove this added section when the 164B is removed from the system.
3. Permanently include in the transmission line a short section equal in length to the electrical length of the line contained in the 164B. (Sierra Model 164-LS Equivalent Line Section is designed for this purpose.) When using the 164B remove the short section from the line.

## 6. MAINTENANCE

6.01 Maintenance instructions presented in this section consist of cleaning and lubrication, inspection, performance verification, troubleshooting, disassembly, repair, and replacement. The tools and test equipment required for these procedures are listed in Appendix D of this manual.

### Cleaning and Lubrication

6.02 The primary line body should be kept free of dirt and foreign matter. Keep the mating surfaces between the primary line and the plug-in element clean. *Lubricate with a thin film of "Lubriplate" or similar lubricant as necessary.*

**CAUTION:** No attempt should be made to clean the coupling loop since any distortion in shape will destroy the instrument calibration. Set the power range selector knob at the highest power range whenever the element is handled. Keep the plastic cap on the end of the element whenever it is not in the instrument.

### Inspection

6.03 At intervals not greater than six months, and preferably at each time of use, inspect the components of the Bi-Directional Power Monitor Set as follows:

6.04 Bi-Directional Power Monitor. Inspect for:

1. Broken or frayed strap.
2. Broken or frayed meter cable assembly.
3. Missing VSWR CAL knob.
4. Cross-threading or broken or bent center pins on connectors.
5. Broken plug-in element clamp or missing nylon wedges.
6. Cracked meter face or bent pointer.
7. Scored mating surface for plug-in element or deformed center conductor on primary transmission line.

8. Broken latches.

9. Missing bumper feet or case cushions.

6.05 Plug-in Elements. Inspect for:

1. Broken or distorted coupling loop.
2. Missing knob.
3. Missing or illegible frequency correction chart on knobs of Plug-in Elements 181A-250 and 270A-30.
4. Scored bottom surface.

6.06 Carrying Case. Inspect for:

1. Broken handle or latches.
2. Missing feet.
3. Damaged foam insert.

**Performance Verification**

6.07 Verification of the accuracy of the Bi-Directional Power Monitor is beyond the scope of this manual, except for a qualitative test. This test may be performed by inserting the power monitor in an operating system, as described under Paragraph 5, to ascertain that incident power readings can be obtained and that the VSWR CAL control is operative. Every six months the complete equipment should be sent to a calibration facility for actual verification of performance accuracy.

**Troubleshooting**

6.08 If the performance verification procedure described in 6.07 results in zero or obviously incorrect incident power readings, the first step is to determine whether the power monitor or the plug-in element is defective.

**NOTE:** If the incident power reading appears to be incorrect, refer to 5.10 before proceeding.

6.09 To determine whether the power monitor or the plug-in element is defective substitute another like plug-in element for the one in use. If this substitution results in approximately correct incident power readings, the fault is in the plug-in element which was replaced. Otherwise, the power monitor is probably defective. If a similar plug-in element is not available, one of the other plug-in elements supplied with the equipment may be used to determine the faulty component when no incident power reading can be obtained. Since the frequency range, and possibly the power range, of a different plug-in element will obviously be different from the plug-in element under test, the power readings obtained will not be accurate. However, any incident power reading will indicate that the original plug-in element was defective.

6.10 If it appears that the plug-in element is defective, forward the complete equipment to an authorized repair facility. If the power monitor is at fault, refer to Table 6-1.

**Disassembly, Repair, and Replacement**

6.11 Disassembly and replacement of all parts of the power monitor is obvious upon examination of the unit. If the meter or either of the Type N connectors is replaced, the complete equipment must be sent to a calibration facility for verification of calibration. However, the power monitor may be used without calibration with the knowledge that the performance accuracy may be outside the specified limits.

Table 6-1. Bi-Directional Power Monitor Troubleshooting

Symptom	Probable Cause	Remedy
No meter indication for incident or reflected power	Defective meter cable assembly Meter M1 defective	Repair or replace cable assembly Replace M1
	Capacitor C1 shorted Broken pin in input or output connector	Replace C1 Replace connector
Erroneous power readings	Meter M1 defective Switch S1 defective	Replace M1 Replace R1/S1
VSWR CAL control inoperative	Variable resistor R1 or switch S1 defective Resistor R2 open	Replace R1/S1 Replace R2

6.12 On the plug-in elements, the only repair authorized is replacement of the knob.

**7. STORAGE AND RESHIPMENT**

7.01 When preparing the equipment for storage or re-shipment, place all components in the carrying case and be sure that the latches are securely closed. To protect the equipment, enclose the case in a carton (preferably the original shipping carton) or a wooden box. Fill the area around the carrying case with packing material and seal the packing container with strong tape or metal bands. Mark the outside of the container FRAGILE - ELECTRONIC INSTRUMENT.

**8. REPLACEABLE PARTS**

8.01 Standard components have been used in this instrument wherever possible. Both standard and special components may be ordered direct from the factory. When ordering parts always include:

1. Sierra Stock Number.
2. Circuit Reference and Commercial Description.
3. Name, Model and Serial Number of the Instrument.

Table 8-1. Replaceable Parts List

Ref. Desig.	Description	Sierra Stock No.	Mfr	Mfr Part No.
	MODEL 164B			
C1	CAPACITOR, Ceramic, 0.01 µF ± 20%, 600 Vdc	901420103	Centralab	DD6-103
1	CONNECTOR, Female, type N	914600013	Sierra	
2	CONNECTOR, Male, type N	914600012	Sierra	
M1	METER, 25 microamperes	911800113	Sierra	
P1	PLUG, Male, type MB	914600088	Amphenol	48800
R1	POTENTIOMETER, Composition, 10K ohms, audio taper, with SPST switch	907900167	Sierra	
R2	RESISTOR, Fixed, composition, 150 ohms ± 5%, 1/2 W	905000151	MIL Std	RCR20G15IJS
S1	Part of R1			
	KNOB, Instrument	916000020	Kurz-Kasch	S645-3L
	BUMPER, Foot, rubber	915600001	Alasco Rubber and Plastics	2197W
	CUSHION, Case, rubber	915400029	Sierra	
	STRAP, Leather	918100002	Sierra	
	CAP, CONNECTOR, protective	917300331	Protective Closures	EC-10
	MODEL 270A-30			
	KNOB	916000010	Sierra	
	DECAL, Frequency correction	919500109	Sierra	
	CAP, Protective	917300104	Protective Closures	221
	MODEL 181A-250			
	KNOB	916000010	Sierra	
	DECAL, Frequency correction	919500188	Sierra	
	CAP, Protective	917300104	Protective Closures	221
	MODEL 181A-1000			
	KNOB	916000010	Sierra	
	DECAL, Arrow	919500081	Sierra	
	CAP, Protective	917300104	Protective Closures	221



## APPENDIX A REFERENCES

---

DA Pam 310-4	Index of Technical Manuals, Technical Bulletins, Supply Manuals (Types 7, 8, and 9), Supply Bulletins, and Lubrication Orders.
DA Pam 310-7	US Army Equipment Index of Modification Work Orders.
TB 43-180	Calibration Requirements for the Maintenance of Army Materiel.
TM 38-750	The Army Maintenance Management System (TAMMS).
TM750-244-2	Procedures for Destruction of Electronics Materiel to Prevent Enemy Use (Electronics Command).
TM 11-6625-433-15	Organizational, Direct Support, General Support, and Depot Maintenance Manual; Wattmeter AN/URM-98 and AN/URM-98A (NSN 6625-00-566-4990).
TM 11-6625-2941-14&P	Operator, Organizational, Direct Support and General Support Maintenance Manual (Including Repair Parts and Special Tools List) for Counter, Electronic, Digital Readout AN/USM-459 (HP Model 5328A/E42) (NSN 6625-01-061-8928).



## APPENDIX D

### MAINTENANCE ALLOCATION

---

#### Section I. INTRODUCTION

##### D-1. General.

This appendix provides a summary of the maintenance operations for AN/URM-120A. It authorizes categories of maintenance functions on repairable items and components and the tools and equipment required to perform each function. This appendix may be used as an aid in planning maintenance operations.

##### D-2. Maintenance Function.

Maintenance functions will be limited to and defined as follows:

*a. Inspect.* To determine the serviceability of an item by comparing its physical, mechanical, and/or electrical characteristics with established standards through examination.

*b. Test.* To verify serviceability and to detect incipient failure by measuring the mechanical or electrical characteristics of an item and comparing those characteristics with prescribed standards.

*c. Service.* Operations required periodically to keep an item in proper operating condition, i.e., to clean (decontaminate); to preserve, to drain, to paint, or to replenish fuel, lubricants, hydraulic fluids, or compressed air supplies.

*d. Adjust.* To maintain, within prescribed limits, by bringing into proper or exact position, or by setting the operating characteristics to the specified parameters.

*e. Align.* To adjust specified variable elements of an item to bring about optimum or desired performance.

*f. Calibrate.* To determine and cause corrections to be made or to be adjusted on instruments or test measuring and diagnostic equipments used in precision measurement. Consists of comparisons of two instruments, one of which is a certified standard of known accuracy, to detect and adjust any discrepancy in the accuracy of the instrument being compared.

*g. Install.* The act of emplacing, seating, or fixing into position an item, part, module (component or assembly) in a manner to allow the proper functioning of the equipment or system.

*h. Replace.* The act of substituting a serviceable like type part, subassembly, or module (component or assembly) for an unserviceable counterpart.

*i. Repair.* The application of maintenance services (inspect, test, service, adjust, align, calibrate, replace) or other maintenance actions (welding, grinding, riveting, straightening, facing, remachining, or resurfacing) to restore serviceability to an item by correcting specific damage, fault, malfunction, or failure in a part, subassembly; module (component or assembly), end item, or system.

*j. Overhaul.* That maintenance effort (service/action) necessary to restore an item to a completely serviceable/operational condition as prescribed by maintenance standards (i.e., DMWR) in appropriate technical publications. Overhaul is normally the highest degree of maintenance performed by the Army. Overhaul does not normally return an item to like new condition.

*k. Rebuild.* Consists of those services/actions necessary for the restoration of unserviceable equipment to a like new condition in accordance with original manufacturing standards. Rebuild is the highest degree of materiel maintenance applied to Army equipment. The rebuild operation includes the act of returning to zero those age measurements (hours, miles, etc.) considered in classifying Army equipments/components.

##### D-3. Column Entries.

*a. Column 1, Group Number.* Column 1 lists group numbers, the purpose of which is to identify components, assemblies, subassemblies, and modules with the next higher assembly.

*b. Column 2, Component/Assembly.* Column 2 contains the noun names of components, assemblies, subassemblies, and modules for which maintenance is authorized.

*c. Column 3, Maintenance Functions.* Column 3 lists the functions to be performed on the item listed in column 2. When items are listed without maintenance functions, it is solely for purpose of having the group numbers in the MAC and RPSTL coincide.

*d. Column 4, Maintenance Category.* Column 4 specifies, by the listing of a "work time" figure in the appropriate subcolumn(s), the lowest level of maintenance authorized to perform the function listed in column 3. This figure represents the active time required to perform that maintenance function at the indicated category of maintenance. If

the number or complexity of the tasks within the listed maintenance function vary at different maintenance categories, appropriate "work time" figures will be shown for each category. The number of task-hours specified by the "worktime" figure represents the average time required to restore an item (assembly, subassembly, component, module, end item or system) to a serviceable condition under typical field operating conditions. This time includes preparation time, troubleshooting time, and quality assurance/quality control time in addition to the time required to perform the specific tasks identified for the maintenance functions authorized in the maintenance allocation chart. Subcolumns of column 4 are as follows:

- C - Operator/Crew
- O - Organizational
- F - Direct Support
- H - General Support
- D - Depot

*e. Column 5, Tools and Equipment.* Column 5 specifies by code, those common tool sets (not individual tools) and special tools, test, and support equipment required to perform the designated function.

*f. Column 6, Remarks.* Column 6 contains an alphabetic code which leads to the remark in section IV, Remarks, which is pertinent to the item opposite the particular code.

#### **D-4. Tool and Test Equipment Requirements (Sect. III)**

*a. Tool or Test Equipment Reference Code.* The numbers in this column coincide with the numbers used in the tools and equipment column of the MAC. The numbers indicate the applicable tool or test equipment for the maintenance functions.

*b. Maintenance Category.* The codes in this column indicate the maintenance category allocated the tool or test equipment.

*c. Nomenclature.* This column lists the noun name and nomenclature of the tools and test equipment required to perform the maintenance functions.

*d. National/NATO Stock Number.* This column lists the National/NATO stock number of the specific tool or test equipment.

*e. Tool Number.* This column lists the manufacturer's part number of the tool followed by the Federal Supply Code for manufacturers (5-digit) in parenthesis.

#### **D-5 . Remarks (Sect. IV)**

*a. Reference Code.* This code refers to the appropriate item in section II, column 6.

*b. Remarks.* This column provides the required explanatory information necessary to clarify items appearing in section II.

SECTION II MAINTENANCE ALLOCATION CHART  
FOR  
WATTMETER AN/URM-120A

(1) GROUP NUMBER	(2) COMPONENT/ASSEMBLY	(3) MAINTENANCE FUNCTION	(4) MAINTENANCE CATEGORY					(5) TOOLS AND EQPT.	(6) REMARKS
			C	O	F	H	D		
00	Wattmeter AN/URM- 120A (Sierra 164B-G3) (Test with one of the below couplers)	Inspect		0.2				11	
		Test		0.3				11	
		Test				0.4		8-10	
		Service				0.3		8-10	
		Repair		0.1				8-10	1
		Repair					0.5		1-10
01	Wattmeter TS-1285A/URM-120 (Sierra 164B) (Test with one of the below couplers)	Inspect		0.2				11	
		Test		0.3				11	
		Test				0.4		8-10	
		Service				0.3		8-10	
		Repair		0.1				11	1
		Repair					0.5		8-10
02	Coupler-Detector CU-753A/URM-120 (Sierra 270A-30)	Test					0.2	1-10	3
		Adjust					0.3	1-10	
		Repair					0.4	1-10	
	Coupler-Detector CU-754A/URM-120 (Sierra 181A-250)	Test					0.2	1-10	3
		Adjust					0.3	1-10	
		Repair					0.4	1-10	
	Coupler-Detector CU-755A/URM-120 (Sierra 181A-1000)	Test					0.2	1-10	3
		Adjust					0.3	1-10	
		Repair					0.4	1-10	
03	Case, Carrying, Fiberglass CY-2606A/URM-120 (Sierra 164 B-CC)	Replace		0.1				None	
		Repair				0.1		None	
		Repair					0.2	11	

SECTION III TOOL AND TEST EQUIPMENT REQUIREMENTS  
FOR  
WATTMETER AN/URM-120A

TOOL OR TEST EQUIPMENT REF CODE	MAINTENANCE CATEGORY	NOMENCLATURE	NATIONAL/NATO STOCK NUMBER	TOOL NUMBER
1	D	Frequency Counter AN/USM-459	6625-01-061-8926	
2	D	RF Power Signal Generator Micro Dot M447	4931-00-128-1443	
3	D	Directional Coupler NBS Model DC-1/350C-AR	5985-00-165-3072	
4	D	Low Pass Filter 50 MHz Telonic TLC 316-6EF	5915-00-410-1719	
5	D	Indicator, Standing Wave, Ratio AN/USM-37E	6625-00-197-6910	
6	D	Wattmeter AN/URM-98	6625-00-519-2414	
7	D	Thermistor Mount HP 478A	6625-00-886-1955	
8	HD	Digital Voltmeter AN/USM-451	6625-01-060-6804	
9	HD	Dummy Load DA-75	6625-00-177-1639	
10	HD	Tool Kit TK-105	5180-00-610-8177	
11	o	Common tools necessary to the performance of this maintenance function are available to maintenance personnel for the maintenance category listed.		

SECTION IV. REMARKS

REFERENCE CODE	REMARKS
1	<b>Replace knobs.</b>
2	<b>No coupler repair.</b>
3	<b>Couplers are not readily interchangeable with other units.</b>





RECOMMENDED CHANGES TO EQUIPMENT TECHNICAL PUBLICATIONS



THEN... JOT DOWN THE DOPE ABOUT IT ON THIS FORM. CAREFULLY TEAR IT OUT, FOLD IT AND DROP IT IN THE MAIL!

SOMETHING WRONG WITH THIS PUBLICATION?

FROM (PRINT YOUR UNIT'S COMPLETE ADDRESS)

Commander  
Stateside Army Depot  
ATTN: AMSTA-US  
Stateside, N.J. 07703

DATE SENT

10 July 1975

PUBLICATION NUMBER

TM 11-5840-340-12

PUBLICATION DATE

23 Jan 74

PUBLICATION TITLE

Radar Set AN/PRC-76

BE EXACT PIN-POINT WHERE IT IS

PAGE NO	PARA-GRAPH	FIGURE NO	TABLE NO
2-25	2-28		
3-10	3-3		3-1
5-6	5-8		
		F03	

IN THIS SPACE TELL WHAT IS WRONG AND WHAT SHOULD BE DONE ABOUT IT:

Recommend that the installation antenna alignment procedure be changed throughout to specify a 2° IFF antenna lag rather than 1°.

REASON: Experience has shown that with only a 1° lag, the antenna servo system is too sensitive to wind gusting in excess of 25 knots, and has a tendency to rapidly accelerate and decelerate as it hunts, causing strain to the drive train. Hunting is minimized by adjusting the lag to 2° without degradation of operation.

Item 5, Function column. Change "2 db" to "3db."

REASON: The adjustment procedure the the TRANS POWER FAULT indicator calls for a 3 db (500 watts) adjustment to light the TRANS POWER FAULT indicator.

Add new step f.1 to read, "Replace cover plate removed step e.1, above."

REASON: To replace the cover plate.

Zone C 3. On J1-2, change "+24 VDC to "+5 VDC."

REASON: This is the output line of the 5 VDC power supply. +24 VDC is the input voltage.

PRINTED NAME GRADE OR TITLE AND TELEPHONE NUMBER

SSG I. M. DeSpiritof 999-1776

SIGN HERE

*I. M. DeSpiritof*

DA FORM 2028-2  
1 JUL 79

PREVIOUS EDITIONS ARE OBSOLETE.

PS--IF YOUR OUTFIT WANTS TO KNOW ABOUT YOUR RECOMMENDATION MAKE A CARBON COPY OF THIS AND GIVE IT TO YOUR HEADQUARTERS

STAR-BLIND REPRODUCTION



RECOMMENDED CHANGES TO EQUIPMENT TECHNICAL PUBLICATIONS



THEN... JOT DOWN THE DOPE ABOUT IT ON THIS FORM. CAREFULLY TEAR IT OUT. FOLD IT AND DROP IT IN THE MAIL.

**SOMETHING WRONG WITH THIS PUBLICATION?**

FROM: (PRINT YOUR UNIT'S COMPLETE ADDRESS)

DATE SENT

PUBLICATION NUMBER

PUBLICATION DATE

PUBLICATION TITLE

BE EXACT PIN-POINT WHERE IT IS

PAGE NO	PARA-GRAPH	FIGURE NO	TABLE NO
---------	------------	-----------	----------

IN THIS SPACE TELL WHAT IS WRONG AND WHAT SHOULD BE DONE ABOUT IT:

IF CR. 4100G. PERFORMED IN/

PRINTED NAME GRADE OR TITLE AND TELEPHONE NUMBER

SIGN HERE

DA FORM 2028-2  
1 JUL 79

PREVIOUS EDITIONS ARE OBSOLETE

PS: IF YOUR OUTFIT WANTS TO KNOW ABOUT YOUR RECOMMENDATION MAKE A CARBON COPY OF THIS AND GIVE IT TO YOUR HEADQUARTERS

FILL IN YOUR  
UNIT'S ADDRESS

FOLD BACK

DEPARTMENT OF THE ARMY

OFFICIAL BUSINESS

PENALTY FOR PRIVATE USE, \$300

Commander  
US Army Communications and  
Electronics Materiel Readiness Command  
ATTN: DRSEL-ME-MQ  
Fort Monmouth, New Jersey 07703

TEAR ALONG DOTTED LINES

FOLD BACK

RECOMMENDED CHANGES TO EQUIPMENT TECHNICAL PUBLICATIONS



**SOMETHING WRONG WITH THIS PUBLICATION?**

THEN... JOT DOWN THE DOPE ABOUT IT ON THIS FORM. CAREFULLY TEAR IT OUT. FOLD IT AND DROP IT IN THE MAIL.

FROM (PRINT YOUR UNIT'S COMPLETE ADDRESS)

DATE SENT

PUBLICATION NUMBER

PUBLICATION DATE

PUBLICATION TITLE

BE EXACT PIN-POINT WHERE IT IS

PAGE NO

PARA-GRAPH

FIGURE NO

TABLE NO

IN THIS SPACE TELL WHAT IS WRONG AND WHAT SHOULD BE DONE ABOUT IT:

TEAR ALONG PERFORATED LINE

PRINTED NAME GRADE OR TITLE AND TELEPHONE NUMBER

SIGN HERE

DA FORM 2028-2  
1 JUL 79

PREVIOUS EDITIONS ARE OBSOLETE

P.S. IF YOUR OUTFIT WANTS TO KNOW ABOUT YOUR RECOMMENDATION MAKE A CARBON COPY OF THIS AND GIVE IT TO YOUR HEADQUARTERS

FILL IN YOUR  
UNIT'S ADDRESS

FOLD BACK

DEPARTMENT OF THE ARMY

OFFICIAL BUSINESS

PENALTY FOR PRIVATE USE, \$300

Commander  
US Army Communications and  
Electronics Materiel Readiness Command  
ATTN: DRSEL-ME-MQ  
Fort Monmouth, New Jersey 07703

FOLD BACK

TEAR ALONG DOTTED LINE

RECOMMENDED CHANGES TO EQUIPMENT TECHNICAL PUBLICATIONS



THEN... JOT DOWN THE DOPE ABOUT IT ON THIS FORM. CAREFULLY TEAR IT OUT. FOLD IT AND DROP IT IN THE MAIL.

**SOMETHING WRONG WITH THIS PUBLICATION?**

FROM: (PRINT YOUR UNIT'S COMPLETE ADDRESS)

DATE SENT

PUBLICATION NUMBER

PUBLICATION DATE

PUBLICATION TITLE

BE EXACT PIN-POINT WHERE IT IS

PAGE NO

PARA-GRAPH

FIGURE NO

TABLE NO

IN THIS SPACE TELL WHAT IS WRONG AND WHAT SHOULD BE DONE ABOUT IT:

IF OR ALONG PERFORATED LINE

PRINTED NAME, GRADE OR TITLE AND TELEPHONE NUMBER

SIGN HERE

DA FORM 2028-2  
1 JUL 79

PREVIOUS EDITIONS ARE OBSOLETE

P.S. - IF YOUR OUTFIT WANTS TO KNOW ABOUT YOUR RECOMMENDATION MAKE A CARBON COPY OF THIS AND GIVE IT TO YOUR HEADQUARTERS

FILL IN YOUR  
UNIT'S ADDRESS

FOLD BACK

DEPARTMENT OF THE ARMY

OFFICIAL BUSINESS

PENALTY FOR PRIVATE USE, \$300

Commander  
US Army Communications and  
Electronics Materiel Readiness Command  
ATTN: DRSEL-ME-MQ  
Fort Monmouth, New Jersey 07703

TEAR ALONG DOTTED LINE

FOLD BACK



RECOMMENDED CHANGES TO EQUIPMENT TECHNICAL PUBLICATIONS



THEN... JOT DOWN THE DOPE ABOUT IT ON THIS FORM. CAREFULLY TEAR IT OUT. FOLD IT AND DROP IT IN THE MAIL.

**SOMETHING WRONG WITH THIS PUBLICATION?**

FROM (PRINT YOUR UNIT'S COMPLETE ADDRESS)

DATE SENT

PUBLICATION NUMBER

PUBLICATION DATE

PUBLICATION TITLE

BE EXACT PIN-POINT WHERE IT IS

PAGE NO

PARA-GRAPH

FIGURE NO

TABLE NO

IN THIS SPACE TELL WHAT IS WRONG AND WHAT SHOULD BE DONE ABOUT IT:

TEAR ALONG PERFORATED LINE

PRINTED NAME, GRADE OR TITLE AND TELEPHONE NUMBER

SIGN HERE

DA FORM 2028-2  
1 JUL 79

PREVIOUS EDITIONS ARE OBSOLETE

P.S. - IF YOUR OUTFIT WANTS TO KNOW ABOUT YOUR RECOMMENDATION MAKE A CARBON COPY OF THIS AND GIVE IT TO YOUR HEADQUARTERS.

FILL IN YOUR  
UNIT'S ADDRESS

FOLD BACK

DEPARTMENT OF THE ARMY

OFFICIAL BUSINESS

PENALTY FOR PRIVATE USE, \$300

Commander  
US Army Communications and  
Electronics Materiel Readiness Command  
ATTN: DRSEL-ME-MQ  
Fort Monmouth, New Jersey 07703

FOLD BACK

TEAR ALONG DOTTED LINE

By Order of the Secretary of the Army:

Official:

J.C. PENNINGTON  
Major General, United States Army  
The Adjutant General

EDWARD C. MEYER  
General, United States Army  
Chief of Staff

TM 11-6625-2982-14

DISTRIBUTION:

Active Army

HISA (Ft Monmouth) (21)	USAES (2)
USAINSCOM (2)	USAICS (3)
COE (1)	MAAG (1)
TSG (1)	USARMIS (1)
USAAENBD (1)	USAERDAW (1)
DARCOM (1)	USAERDAA (1)
TRADOC (2)	Ft Gordon (10)
OS Maj Cmd (4)	Ft Carson (5)
TECCOM (2)	Army Dep (1) except
USACC (4)	SAAD (30)
MDW (1)	TOAD (14)
Armies (2)	SHAD (2)
Corps (2)	Ft Gillem (10)
Svc Colleges (1)	USA Dep (1)
USAADS (2)	Sig Sec USA Dep (1)
USASIGS (5)	Ft Richardson (CERCOM Ofc) (2)
USAFAS (2)	Units Org under fol TOE:
USAAFMS (2)	29-207 (2)
USAIS (2)	29-610 (2)

NG: None

USAR: None

For explanation of abbreviations used, see AR 310-50.

